

1. Main technical characteristics

- Flow Rate up to 2.300 l/h
- Pressure up to 10 bar
- Mechanically actuated PTFE diaphragm
- Flow rate adjustment from 0 to 100%
- Stroke Rate: 43 / 86 / 131 / 175 strokes/minute
- Stroke Length: 7 / 8 / 9 / 15 mm
- Diaphragm Diameter: 124 / 140 / 157 / 179 mm
- Motor: 0.55 / 0.75 / 1.1 kW
- Maximum temperature of pumped liquid: 40 °C
- Maximum ambient temperature: 55 °C
- Stroke adjustment with locking system
- Enclosure Protection Class: IP55
- Material of Pump Head:
 - SS 316L
 - PVDF

2. General features

- The Kosmo Series dosing pumps offer a high level of reliability with outstanding value for applications up to 10 Bar and flow rates up to 2.300 l/h.
- A range of dosing pumps that are compact, lightweight, robust and simple designed for low discharge pressures, durability and cost effectiveness, mainly used in water treatment and in the food industry in clean-in-place applications. Designed to provide reduced overall operating costs over time, the mechanically-actuated PTFE diaphragm increases diaphragm life by eliminating the stresses inherent in most pump designs.
- Kosmo models are multipurpose pumps and can handle all known reagents. They are recommended for continuous service and can run dry without any damage to the pump.
- Kosmo pumps incorporate a variable eccentric system minimizing pulsation and shock.
- Kosmo dosing pumps consists of durable, metallic housing designed to withstand tough environments and suitable for a large number of industrial uses other than water treatment, such as the injection of reagents at medium pressure.
- Kosmo pumps have an adjustment of flow rate while running or stopped from 0 to 100%, with a maximum temperature of pumped liquid up to 40 °C aimed at delivering exceptional performance across a wide range of flow and pressure environments.

Kosmo MM2 Series - Mechanical Diaphragm Pump

3. Codification

KOSMO - KEY TO MODEL NUMBER												
Field 1	Field 2	Field 3	Field 4	Field 5	Field 6	Field 7	Field 8	Field 9	Field 10	Field 11	Field 12	
M	M2	F	124	D	21	C	4	0	0	0	0	
Field 1	model											
Field 2	mechanism type											
Field 3	stroke length											
Field 4	diameter											
Field 5	stroke/min											
Field 6	pump head											
Field 7	motor power											
Field 8	motor type											
Field 9	customization											
Field 10	market											
Field 11	stroke reg.											
Field 12	optional											
Field 1	model											
	M	Mechanical Return DIAPHRAGM										
Field 2	mechanism type											
	M1	M1 Mechanical return		MM1								
	M2	M2 Mechanical return		MM2								
Field 3	stroke length	Stroke length [mm]										
	A	2		MM1								
	C	4		MM1								
	D	6.4		MM1								
	E	7.4		MM1								
	F	7		MM2								
	G	8		MM2								
	H	9		MM2								
	I	15		MM2								
Field 4	diameter	Diaphragm [mm]										
	065	65		MM1								
	096	96		MM1								
	124	124		MM1 / MM2								
	140	140		MM1 / MM2								
	157	157		MM2								
	179	179		MM2								
Field 5	stroke/min	Strokes / minute										
	A	24:1		58		MM1						
	B	18:1		78		MM1						
	C	12:1		116		MM1						
	D	32:1		43		MM2						
	E	32:2		86		MM2						
	F	32:3		131		MM2						
	G	32:4		175		MM2						
Field 6	pump head	DIAPHRAGM - Standard Execution										
		head	diaphragm	valve	seat	O-Ring						
	21 / 24	SS316L	PTFE	SS316L	SS316L	FPM / EPDM						
	41 / 44	PVDF	PTFE	CERAMIC	PVDF	FPM / EPDM						
Field 7	motor power	kW	supply	phase		size						
	0	Without motor										
	A	0.25	230/400 Vac		3		71-B5/ MM1					
	B	0.37	230/400 Vac		3		71-B5/ MM1					
	C	0.55	230/400 Vac		3		80-B5/ MM2					
	D	0.75	230/400 Vac		3		80-B5/ MM2					
	E	1.10	230/400 Vac		3		90S-B5/ MM2					
Using the 60 Hz 3phases motor the performances of the pumps will be as follows: Pressure: -20% - Flow Rate: +20%												
Field 8	motor type											
	0	Without motor										
	2	2/3										
	4	4/3 230/400Vac, 50/60Hz, TEFC (Totally Enclosed Fan-Cooled)										
	6	6/3										
	3	2/1										
	5	4/1 230Vac, 50Hz, TEFC (Totally Enclosed Fan-Cooled)										
	7	6/1										
Field 9	customization											
	0	Standard (or without motor)										
	I	Inverter										
	S	Forced Ventilation										
	X	Flame-Proof (Exd II B T4)										
	V	Flame-Proof (Exd II B T4) + Forced Ventilation										
Field 10	market											
	0	Standard										
	6	Asian market										
	7	Brazilian market										
	8	Chinese market										
Field 11	stroke reg.											
	0	Manual										
	A											
Field 12	optional											
	0	Standard										
	A											

Kosmo MM2 Series - Mechanical Diaphragm Pump

4. Specification

KOSMO MM2 Series - EQUIPPED WITH STANDARD MOTOR										
Model	Diameter (mm)	Stroke Length (mm)	Stroke Rate	Flow Rate [l/h]	Max Pressure (bar)	Connections		Motor kW/pole	Gross Weight (Kg)	Wooden Box L W H (mm)
						SS316L	PVDF		SS316L / PVDF	SS316L / PVDF
MM2F124D**C40000	124	7	43	80	10	BSPf 3/4"	BSPf 3/4"	0.55/4	56	700 X 500 X 750
MM2F124F**C40000			131	250						
MM2G124G**C40000		8	450	7						
MM2G140G**C40000	140		175		600					
MM2H157G**C40000	157	9	1.000	4	BSPf 1 1/2"	BSPf 1 1/2"	0.75/4	68		
MM2I179F**D40000	179	15	131						1.600	
MM2I179G**E40000			175	2.300	1.1/4					

- 1) (**) Available wetted parts: SS316L (21/24) and PVDF (41/44) ;
- 2) In addition to the STD motor, it is also can be equipped with VSD motor (Variable Speed Drive) or Flame-Proof motor (Exd IIB T4);
- 3) Tested with water @ 20°C @ 50 Hz; Flow rate values with motor at 50Hz. Multiply by 1.2 for 60 Hz.

5. Liquid End Material

Material	Liquid End Body			
	21	41	24	44
Pump Head	SS 316L	PVDF	SS 316L	PVDF
Diaphragm	PTFE		PTFE	
Seal	FPM		EPDM	
Ball	SS 316L	Ceramic	SS 316L	Ceramic
Ball Seat		PTFE		PTFE

6. Performance curve P [barg] - Q [L/h]

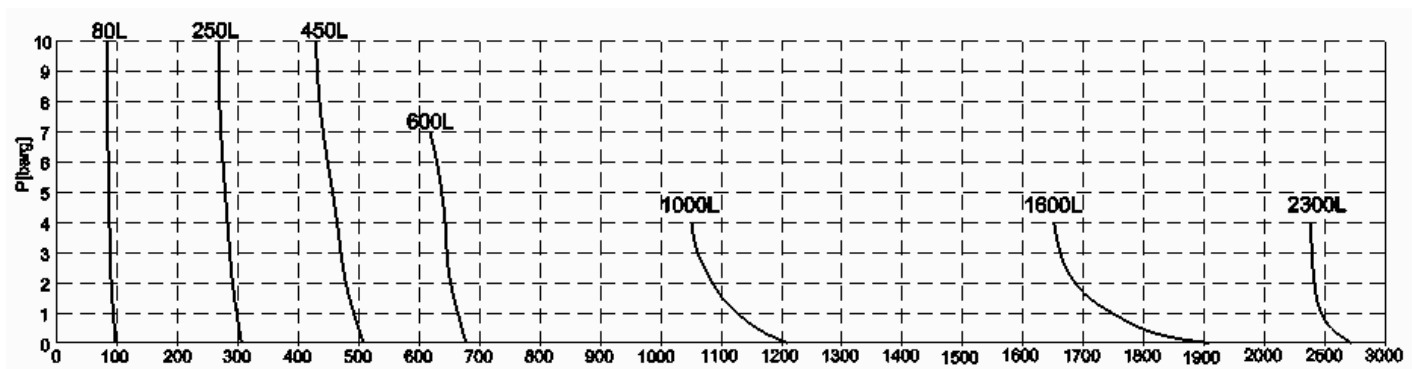

Kosmo MM2 Series - Mechanical Diaphragm Pump

7. Flow rate with Viscous liquids

The MM2 viscosity performance is compared to the water @ 20°C, @max pressure rate; the trail pilot fluid for the viscosity test has been a PAM (polyacrylamide flocculant) polymer.

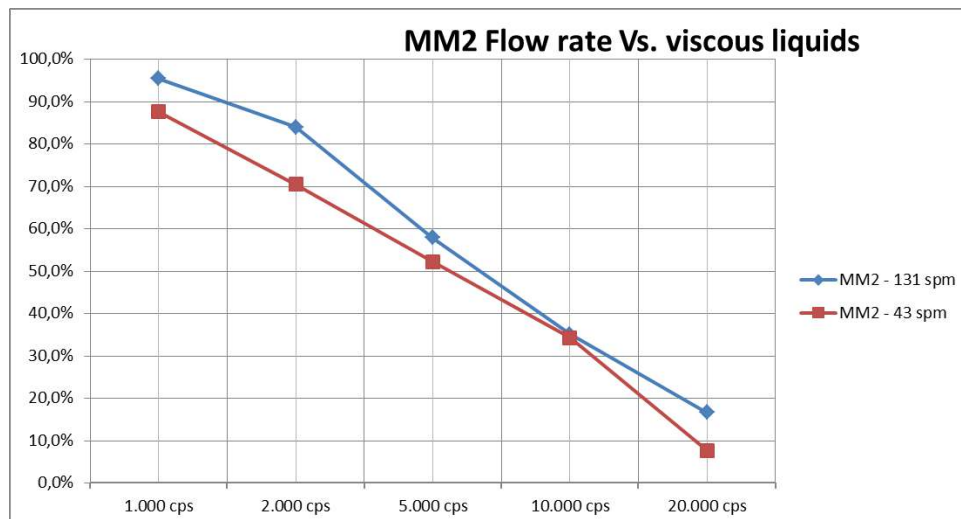

8. Installation Drawing

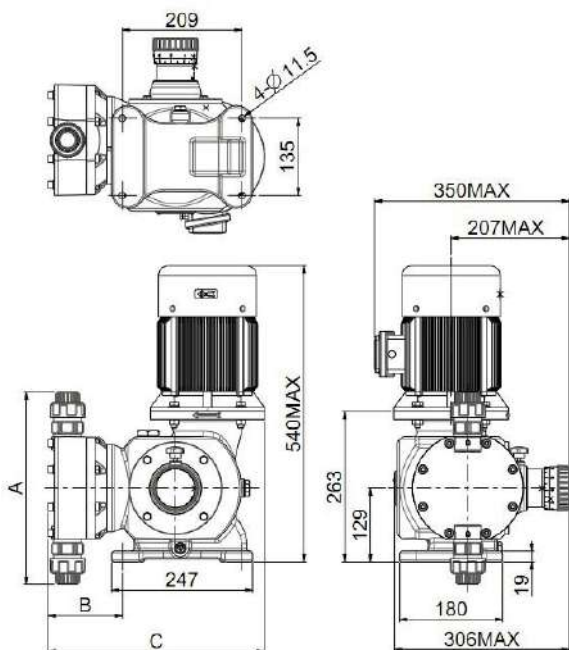

MM2 Pump Head	Diaphragm dia. 124mm				Diaphragm dia. 140mm				Diaphragm dia. 157mm				Diaphragm dia. 179mm			
Material	Connection	A	B	C	Connection	A	B	C	Connection	A	B	C	Connection	A	B	C
PVDF	BSPf 3/4"	293	123	372	BSPf 1"	316	129	377	BSPf 1"	334	130	379	BSPf 1 1/2"	424	148	395
SS316L	BSPf 3/4"	216	108	357	BSPf 1"	251	130	378	BSPf 1"	295	132	381	BSPf 1 1/2"	382	160	407

9. Painting requirements

The anti-corrosion painting process for dosing pump applications requires an entire coating thickness of between 0.06mm and 0.20mm.